

General Radio EXPERIMENTER

VOLUME XX No. 9

FEBRUARY, 1946

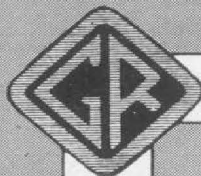

ELECTRICAL MEASUREMENTS AND THEIR INDUSTRIAL APPLICATIONS

<i>Also</i>	
IN THIS ISSUE	
	<i>Page</i>
A HANDY PAIR OF BRIDGES	3
PERSONNEL	8

THE CONSTANT WAVEFORM FREQUENCY METER

● IN THE COMMUNICATIONS INDUSTRY there has been a steadily growing demand for direct-reading frequency meters. Various counting type circuits utilizing thyratrons, multivibrators, etc. have been designed to provide direct frequency

indications on a meter scale. General Radio TYPE 834-A Frequency Meter, for instance, which has been a very popular instrument, is of the thyatron type. The range of this instrument, however, extends only up to 5 kilocycles which, for many applications, is inadequate.

In many laboratory and production measurements, as well as in the monitoring of high-frequency radio transmitters, much higher frequencies must be measured, and, for a general-purpose instrument, a range of about 50 kilocycles is desirable. To provide this greater range the General Radio Company has developed a new circuit* which is considerably simpler than those commonly used.

One of the simplest circuits that can be used for measuring frequency is a resistance-reactance combination, which has a frequency-dependent transmission characteristic. Figure 2 shows the elementary form of such a circuit with a rectifying diode included. When the resistance, R (including the diode resistance), is made small compared to the reactance of the capacitor, C , the current, and hence the voltage drop across R , will be directly proportional to the capacitance and to

*U. S. Patent No. 2,362,503

FIGURE 1. Panel view of the TYPE 1176-A Electronic Frequency Meter.

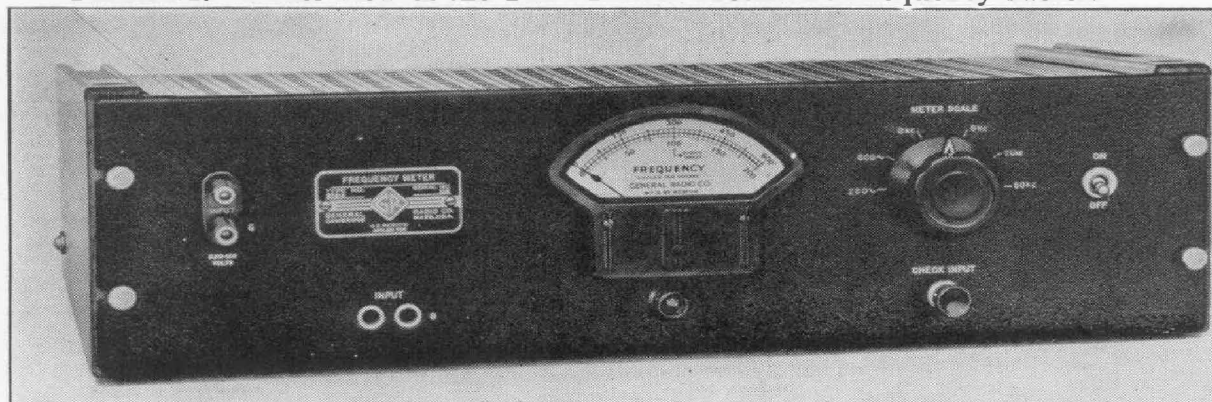

the frequency. Such a device can be made to provide a substantially linear variation in transmission as a function of frequency, which gives a desirable linear meter scale. It has also the important advantage that the calibration will depend mainly upon a single capacitance-resistance combination, and consequently will have a high degree of stability. If, therefore, provision is made to impress upon such a circuit a waveform which is constant in amplitude and wave shape, regardless of frequency, a simple vacuum-tube voltmeter connected across the resistor will give an accurate indication of the transmission and consequently of frequency.

The simplest waveform to generate is a square wave. The problem becomes, therefore, mainly one of designing suitable limiting and wave shape circuits so as to reduce to a minimum any error resulting from changes in amplitude or waveform of the signal applied to the RC circuit.

The new TYPE 1176-A Frequency Meter operates on this principle. As shown in the elementary schematic diagram of Figure 3, the circuit consists of a series of limiting amplifiers and diodes, with automatic biasing circuits which provide satisfactory operation over a wide range of input voltages ranging from $\frac{1}{4}$ volt to 150 volts, and for practically any type of waveform which will ordinarily be encountered. A push button is provided on the panel to check that the input voltage is sufficient to insure accurate readings.

FIGURE 3. Elementary schematic diagram of the TYPE 1176-A Frequency Meter.

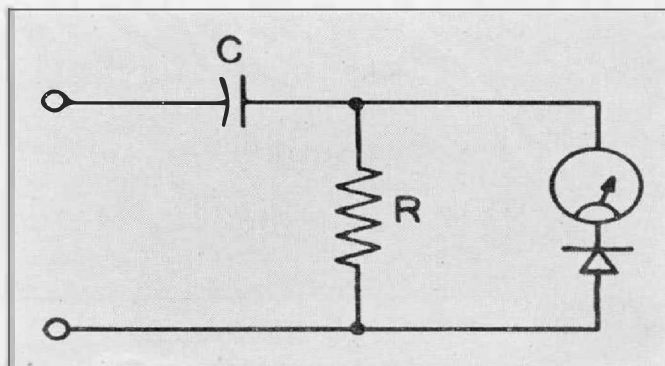
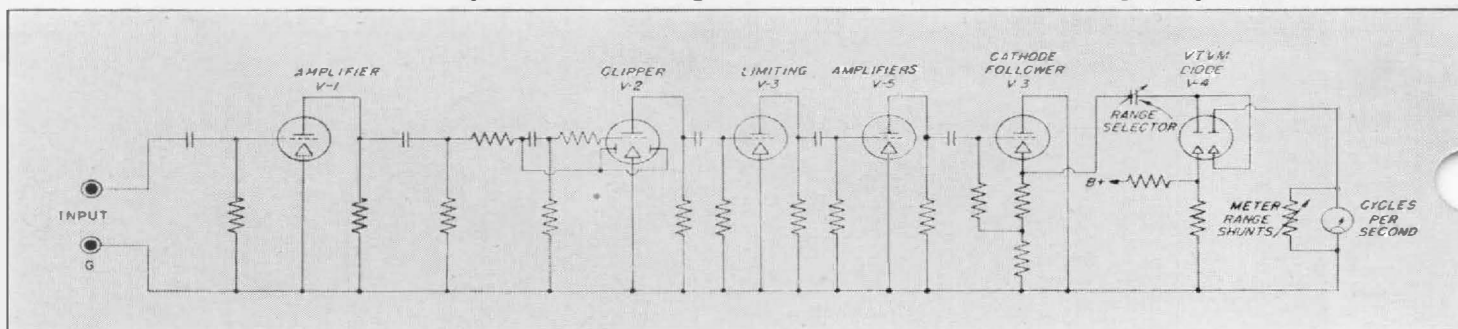

FIGURE 2. Simple frequency-dependent circuit, consisting of a capacitor and a resistor in series.

The RC circuit is switched to provide six ranges giving full-scale meter deflection of 200, 600, 2000, 6000, 20,000, and 60,000 cycles. The indicating meter is actuated by a full wave vacuum-tube meter circuit, which provides additional compensation for any dissymmetry in the waveform after limiting. The circuit is provided with voltage regulation, and the heater current for the vacuum-tube voltmeter is also regulated. Thus a high degree of stability and accuracy is assured, and the permanence of the calibration is such that no trimmer adjustments are required on the front panel.

The meter scale is linear, and provision is made for the addition of an external extension meter or recorder through a multipoint connector at the rear. Two sets of input terminals are provided on the panel and another set on the multipoint connector at the rear. Plugging into the W. E. panel jacks automatically disconnects the rear terminals. The full-scale current is 0.2 milliamperes.

In a time of rising prices, the sim-





plicity of the new frequency meter allows it to be sold at a price actually lower than the older narrower range type. While designed originally as a part of a new police and aviation radio mon-

itor, the TYPE 1176-A Frequency Meter will also be catalogued separately to replace the TYPE 834 Electronic Frequency Meter.

— H. H. SCOTT

SPECIFICATIONS

Range: 25–60,000 cycles per second in six ranges. Full-scale values are 200, 600, 2000, 6000, 20,000, 60,000 cycles.

Accuracy: ± 2 cycles $\pm 2\%$ of full scale, for all ranges. When operating on the 60,000-cycle range, with less than 0.5 volt input, the accuracy becomes $\pm 3\%$ of full scale.

Input Voltages: 0.25–150 volts.

Input Resistance: 500,000 ohms, for all ranges. One side grounded.

Input Waveform: The readings are substantially independent of waveform, so long as the dissymmetry of the positive and negative portions of the wave is less than 8:1.

Power Supply: 105–125 (or 210 to 250) volts, 50-60 cycles.

Power Input: Approximately 50 watts.

Vacuum Tubes:

1—type 6H6	1—type 6SN7-GT
1—type 6SQ7	1—type 6J5
1—type 6X5	2—type 6SJ7
1—type 6V6	1—type OA3/VR75
	1—Amperite 3-4

Mounting: Relay-rack panel; walnut end frames are available to convert to table mounting.

Accessories Supplied: Spare fuses; spare pilot lamp, multi-point connector, all vacuum tubes.

Dimensions: Panel, 19 x 5 $\frac{1}{4}$ inches, depth behind panel, 11 $\frac{1}{4}$ inches.

Net Weight: 19 $\frac{1}{2}$ pounds.

Type	Code Word	Price
1176-A	Frequency Meter..... TIMID	\$185.00

A HANDY PAIR OF BRIDGES

● **IN THE LABORATORY** or on the production line the need frequently arises for the rapid measurement of capacitors or inductors with a moderate degree of precision. For this purpose, a pair of twin units, the TYPE 1614-A Capacitance Bridge and the TYPE 1631-A Inductance Bridge, is now offered, each designed to accomplish a specific purpose at a moderate price consistent with reliable performance and simplicity of operation. To a first approximation these new bridges supply, as separate units and in more portable form, the reactance bridge circuits available in the popular General Radio Impedance Bridge, TYPE 650-A. They do not supersede, but rather supplement the latter.

Each of these self-contained bridges is housed in a covered walnut cabinet measuring 13 $\frac{1}{2}$ " x 8 $\frac{1}{2}$ " x 7" and provided with a handle on one end for easy portability (13 pounds). Mounted on slip hinges, these covers can be opened for exposing the operating panel or removed entirely if desired. Explicit operating instructions are attached to the inside of the cover. While the bridges must be operated with their control panels approximately horizontal, they can be transported or stored in any position.

Either bridge is energized by a one-kilocycle microphone-driven reed "hummer," operated by dry cells which are housed in the cabinet. The hummer unit is provided with a flexible mounting

which minimizes injury from shock and reduces the hum tone transmitted to the instrument panel and, hence, into the operating room.

Sufficient bridge sensitivity permits a pair of headphones, without amplification, to be used as the null-balance detector. A pocket compartment is provided in the cabinet for storing these phones. In order that these bridges shall be available for instant use at all times, the phones are internally attached to the instrument so that they cannot conveniently be "borrowed" for another job and thus, perhaps, not be available when wanted.

The main six-inch control dial of each bridge is provided with a slow-motion drive to facilitate accurate adjustment. This dial drives a six-inch rheostat logarithmically wound so that, over the major range of the dial covering two decades of capacitance (1614-A) or of inductance (1631-A), these values can be read with nearly the same fractional accuracy at all scale points. Sufficient overlap is provided at both the upper and lower extremities of this double-

decade dial. These large rheostats are equipped with an adjustment cam which permits a differential displacement between the rheostat arm and the control dial, a feature which affords an accurate calibration of each individual dial in the manufacture of these instruments.

The 1614-A Capacitance Bridge

While the Schering bridge provides the most precise measurement of capacitance, it requires expensive adjustable capacitors. Nominal precision can readily be obtained by what is known as the series-resistance bridge circuit depicted in Figure 2. One bridge arm consists of the large logarithmic rheostat controlled by the main dial, which is calibrated directly in microfarads. The multiplier arm consists of one of three fixed resistors selected by a triple position panel switch and providing the following ranges:

Multiplier	Capacitance Range
1.0	1 to 100 μf
0.01	.01 to 1 μf
0.0001	.0001 to .01 μf
0.0001	10 to 100 $\mu\mu\text{f}^*$

*Reduced precision on this lowest decade.



FIGURE 1. View of the TYPE 1631-A Inductance Bridge. Telephones are permanently attached to the instrument, and all necessary operating instructions are mounted in the cover. The TYPE 1614-A Capacitance Bridge is similar in appearance.

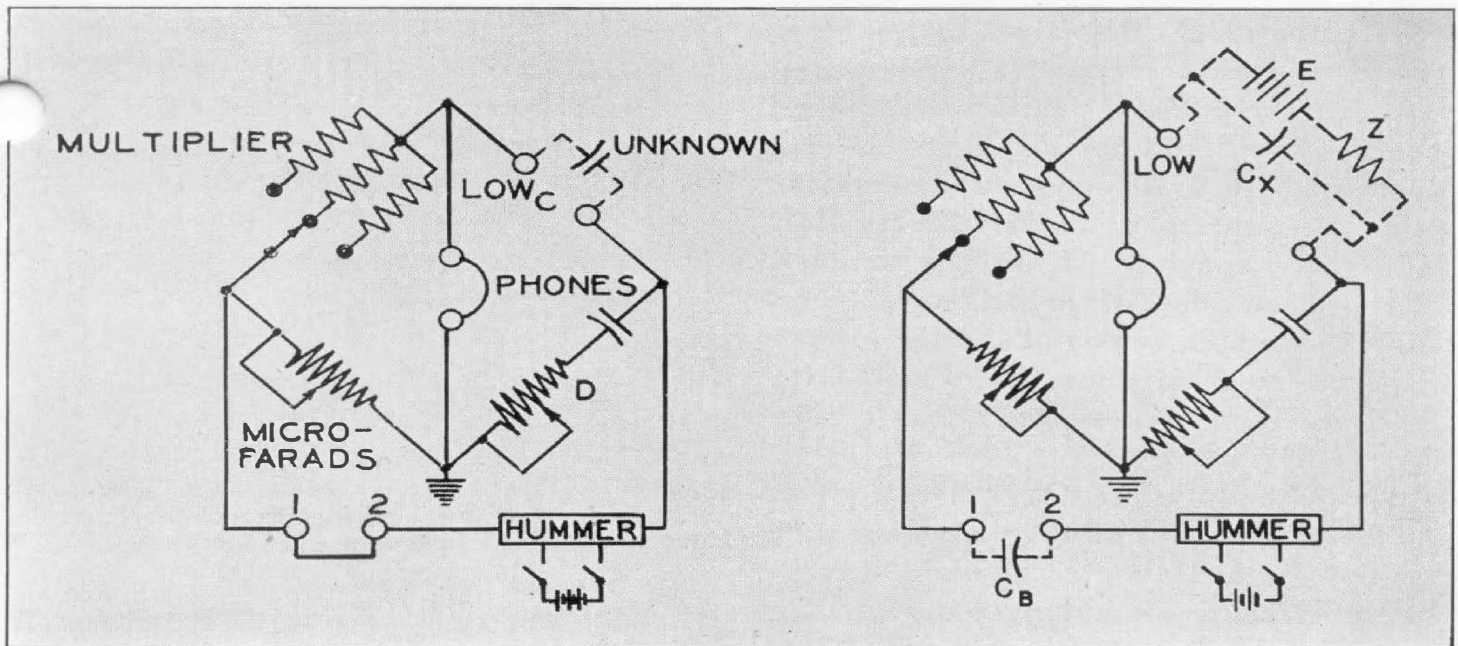

FIGURE 2. Schematic wiring diagram of the TYPE 1611-A Capacitance Bridge.

This available range is thus ten millionfold. The multiplier switch also changes (not shown) the operating impedance of the hummer in the interests of sensitivity. The arm opposite the microfarads rheostat contains the unknown capacitor under test, while the arm opposite the multiplier contains a high grade standard capacitor in series with a smaller logarithmic rheostat D . This rheostat is adjusted by the smaller control dial which is calibrated directly in the dissipation factor of the unknown over a working range from 0 to 0.45. Bridge balance is easily attained by the joint manipulation of the MICROFARADS and D dials, with the multiplier initially set for the appropriate range.

The necessary parameter relationships to achieve a balance of this capacitance bridge are expressed by the two simultaneous equations:

$$C_x = \left(\frac{C_1}{R_3} \right) R_2 \quad (1)$$

and

$$D_x = (2\pi f C_1) R_1 \quad (2)$$

where C_1 is the standard capacitor, R_1

FIGURE 3. Bridge connections for capacitance measurement with polarizing voltage.

the resistance (small rheostat) in series with C_1 , R_2 is the large rheostat and R_3 is the multiplier value used. For a fixed value of C_1 it will be seen that the existence of R_2 , in Equation (1) only, permits the large dial to be calibrated in terms of C_x for a specific C_1/R_3 ratio, while changing the multiplier R_3 , also uniquely in Equation (1), by double decade steps changes one hundredfold the magnitude of C_x for any specific R_2 value. Likewise the existence of R_1 , in Equation (2) only, permits the small dial to be calibrated directly in terms of D_x for a specific value of frequency f , — in this case one kilocycle.

By a slight modification indicated in Figure 3, the 1614-A Bridge can be used to measure electrolytic capacitors having an applied polarizing voltage. A suitable d-c voltage source E in series with a resistor Z is applied, with the correct polarity, across the terminals of C_x . To eliminate errors, the value of Z should exceed 100 times the reactance of C_x at 1000 cycles. If C_x passes any leakage current, the actual voltage on C_x will be

the value of E diminished by the drop in Z . For this purpose, a jumper connecting the internal points 1 and 2 must be removed and a capacitor C_B (not provided) of $2 \mu f$ (or larger) inserted in this position. Space is available for storing this capacitor within the cabinet. For ordinary uses of the bridge, C_B (Figure 2) should be removed and the jumper replaced to achieve maximum sensitivity and precision of balance.

The 1631-A Inductance Bridge

There are several bridge circuits, such as the Owen, Hay, etc., available for the measurement of inductance, but for measuring inductors whose Q value does not exceed about 50, the most convenient circuit is that of the Maxwell bridge depicted in Figure 4. One bridge arm consists of the large logarithmic rheostat controlled by the main dial which is calibrated directly in henrys. Opposite this is the multiplier arm comprising one of three fixed resistors selected by a triple-position panel switch and providing the following ranges:

Multiplier	Inductance Range
1.0	1 to 100 henrys
0.01	.01 to 1 henrys
0.0001	.0001 to .01 henrys
0.0001	10 to 100 microhenrys*

The available range is thus ten million-fold. The multiplier switch also changes (not shown) the operating impedance of the hummer in the interests of sensitivity. A third arm of this bridge consists of the unknown inductor under test. The opposite arm contains a high-grade standard capacitor which is shunted by a smaller logarithmic rheostat Q . This rheostat is adjusted by the smaller control dial which is calibrated directly in terms of the storage factor of the unknown over a working range from 0 to

*Reduced precision on this lowest decade

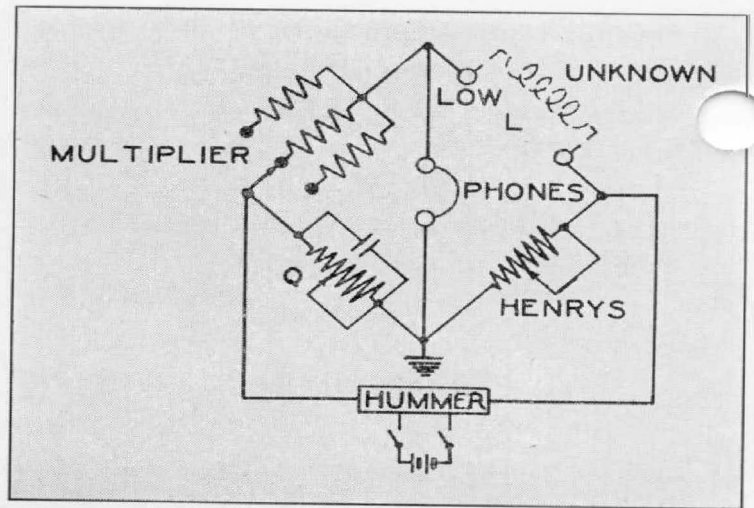

FIGURE 4. Schematic wiring diagram of TYPE 1631-A Inductance Bridge.

45. With the multiplier initially set for the appropriate range, a bridge balance is easily attained by a joint manipulation of the henrys and Q dials.

A balance of this Maxwell bridge is indicated by the two simultaneous equations:

$$L_x = (R_3 C_1) R_2 \tag{3}$$

$$Q_x = (2\pi f C_1) R_1 \tag{4}$$

wherein C_1 is the standard capacitor, R_1 the resistance (small rheostat) in parallel with C_1 , R_2 is the large rheostat and R_3 is the multiplier value used. Starting with a fixed C_1 value, since R_2 is uniquely in Equation (3) the large dial can be calibrated in terms of L_x for a specific $R_3 C_1$ product, while changing the multiplier R_3 by a double decade step modifies one hundredfold the magnitude of C_x for any specific R_2 value. Likewise, the existence of R_1 , in Equation (4) only, permits the small dial to be calibrated in terms of Q_x for a specific value of frequency f , — in this case one kilocycle.

Parenthetically, Equation (4) sets a maximum limit to the Q_x value attainable, with a specific fC product, as determined by the maximum resistance R_1 for which it is practical to wind a



calibrated rheostat. Higher values of Q_x may be measured by the Hay bridge in which the standard capacitor and the small-valued Q rheostat are in series. The Hay bridge, however, requires a troublesome correction factor to be applied to the inductance scale values of low Q inductors. Hence the Maxwell bridge was chosen for this purpose, on the assumption that rarely do the 1-kc Q values of inductors exceed 45.

It should be noted that when iron-cored inductors are measured on such a

bridge as this, having no control over the applied generator voltage, the L and Q values obtained are the 1 kc values corresponding to an arbitrary degree of magnetization in the core which is indeterminate unless a vacuum-tube voltmeter is applied across the terminals of the inductor in the balanced bridge. If the ferromagnetic core does not contain an appreciable air gap, this indeterminate magnetization will, in general, considerably exceed that corresponding to initial permeability.

— HORATIO W. LAMSON

SPECIFICATIONS FOR TYPE 1614-A CAPACITANCE BRIDGE

Capacitance: Range, 10 $\mu\mu\text{f}$ to 100 μf in three steps: 10 $\mu\mu\text{f}$ to 10,000 $\mu\mu\text{f}$; 0.01 μf to 1.0 μf ; and 1.0 $\mu\mu\text{f}$ to 100 μf .

Accuracy: $\pm 2\%$, except on the lowest range, where, after the zero capacitance of 9 $\mu\mu\text{f}$ is subtracted, the accuracy is $\pm(2\mu\mu\text{f} + 2\%$ of the dial reading).

Dial Calibration: Approximately logarithmic (uniform fractional accuracy) over two main decades, with a compressed lower decade which is used only for measurements below 100 $\mu\mu\text{f}$.

Dissipation Factor: Range, 0 to 45%. Accuracy: On the lowest range, the error, expressed in per cent dissipation factor, is $\pm(2\% + 0.1 \times \text{dial reading})$; on the other two ranges, $\pm(0.2\% + 0.1 \times \text{dial reading})$.

Frequency: The internal oscillator furnishes

the necessary bridge power at a frequency of 1000 cycles $\pm 5\%$.

Power Supply: 6-volt dry battery. Two Burgess F2BP units connected in series are recommended, and are supplied with the instrument. Space for these is provided in the cabinet.

Accessories Supplied: Head telephones and batteries.

Accessories Required: When a d-c polarizing voltage is used, a 2 μf blocking capacitor is required. This condenser is not supplied with the instrument, but space for a General Electric TYPE 55X-629 is provided in the cabinet.

Mounting: Walnut cabinet with removable hinged cover.

Dimensions: 13½ x 8½ x 7 inches, overall.

Net Weight: 13¼ pounds.

Type	Code Word	Price
1614-A	Capacitance Bridge..... LAPEL	\$90.00

SPECIFICATIONS FOR TYPE 1631-A INDUCTANCE BRIDGE

Inductance: Range, 10 μh to 100 h in 3 steps, 10 μh to 10,000 μh ; 0.01 h to 1 h; and 1 h to 100 h.

Accuracy: $\pm 2.5\%$ of dial reading between 100 μh and 10 h. Below 100 μh the error varies inversely as the magnitude of the unknown. Above 10 h the error increases to $\pm 10\%$ dial reading at 100 h.

Dial Calibration: Approximately logarithmic (uniform fractional accuracy) over two main decades, with a compressed lower decade

which is used only for measurements below 100 μh .

Q: Range, 1 to 45. Accuracy, $\pm 10\%$ of dial reading for values of Q between 2 and 10. For higher values the error increases progressively to $\pm 15\%$ at a Q of 45. For lower values, the error increases to $\pm 20\%$ at a Q of 1.

Other specifications are identical with those for TYPE 1614-A Capacitance Bridge.

Type	Code Word	Price
1631-A	Inductance Bridge..... LARVA	\$98.00

PERSONNEL

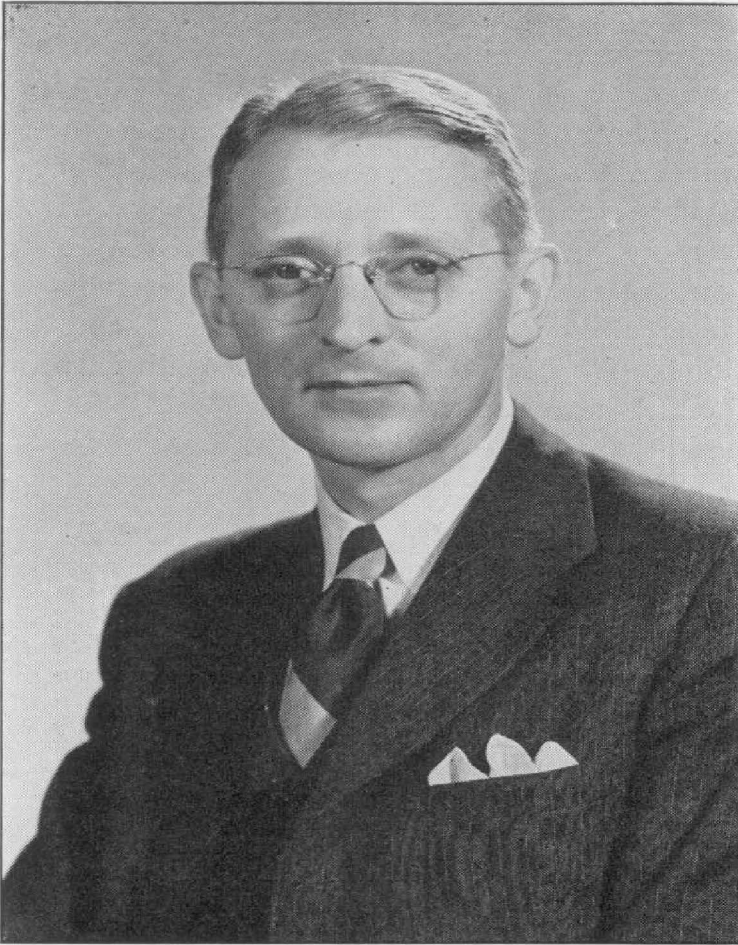

Kipling Adams, who takes charge of General Radio's Chicago office.

● **MESSRS.** Hermon H. Scott, Lucius E. Packard and Raymond W. Searle have severed their connections with General Radio to form a new com-

pany for the present purpose of manufacturing technical equipment of a type not made by General Radio. They have located in Waltham, Massachusetts.

Mr. Scott, who came with us in 1931, was a development engineer, and Mr. Searle was one of our production foremen. Mr. Packard, who joined our engineering staff in 1936, has been in charge of our District Office at 920 South Michigan Avenue in Chicago since its organization over two years ago.

That very active office is now managed by Mr. Kipling Adams, who for the past several years has been Assistant Manager of the Service Department. Mr. Adams received his technical education at the Massachusetts Institute of Technology and came to the General Radio Company in 1934. During his first few years here he was with the Calibration Laboratory where final tests and calibrations are made on our instruments, and since then he has been in the Service Department. These activities have given him an intimate and well-rounded knowledge of General Radio products, which qualifies him to be of the maximum assistance to our many friends in the Chicago and Middle Western area.

GENERAL RADIO COMPANY

275 MASSACHUSETTS AVENUE

CAMBRIDGE 39

MASSACHUSETTS

TELEPHONE: TROWBRIDGE 4400

BRANCH ENGINEERING OFFICES

NEW YORK 6, NEW YORK
90 WEST STREET
TEL.—WORTH 2-5837



LOS ANGELES 38 CALIFORNIA
1000 NORTH SEWARD STREET
TEL.—HOLLYWOOD 6321

CHICAGO 5, ILLINOIS
920 SOUTH MICHIGAN AVENUE
TEL.—WABASH 3820